

# AXPERT OPTI torque

The High Performance  
Electronic Digital Soft Starter -  
Internal Bypass Series



**15...1065 A, 3.7...1000 kW (5...1340 HP)  
200...690 V Supply Voltage**



## Features

- 3-Phase control
- Universal control supply 90...270V AC 50/60Hz
- Most advanced integrated electronic motor over load and over current protections
- Wide range class 2 to 30 electronic overload
- In-built Energy Meter, displays kWh & MWh
- In-line (3-wire) / Inside Delta (6-wire) operating modes
- Motor PTC connection for motor over temperature protection
- Conformal coating on all circuit boards (PCBs) as standard to protect against 3C3 environment
- Commissioning mode for easy commissioning
- RS-485 Modbus Communication with Axpert-Communicator software for remote monitoring
- Fully Configurable Analog and Digital Inputs / Outputs
- Stores last 20 Diagnostic faults with of 8 key operational parameter values and status at the time of fault
- Senses current in all three phases and provides Current, Voltage & Power information; protection even in bypass mode
- Energy efficient design - Cooling fan control as per heat-sink temperature. This will increase fan life and also reduce the power consumption
- Digital Operation Panel 5 digit, 7-segment LED display (IP65) with 2 decimal points, Unit indication, Start Mode, Start control, Bypass and Starter's status LEDs display, 9-Key Keypad, 3-LED for Run, Stop, Fault
- In-built PLC Function for logical operations and interlocking, with Axpert-Drive logic programming tool for easy programming

# Standard SPECIFICATIONS

<b>Power Source</b>		4: 200...480 VAC or 6: 200...690 VAC, 3-Phase, 3-Wire, 50/ 60 Hz																										
<b>External Control Supply</b>		1-Phase, 50/60 Hz, 90...270 V or 115 V or 230 V (Refer order code for control supply detail)																										
<b>Tolerance</b>		Voltage tolerance: -15%, +10%, Frequency tolerance: ±5%																										
<b>AMT-OT-iB-XXXXA-4/6-X-X</b>		<b>0015</b>	<b>0023</b>	<b>0028</b>	<b>0034</b>	<b>0044</b>	<b>0052</b>	<b>0065</b>	<b>0078</b>	<b>0087</b>	<b>0096</b>	<b>0110</b>	<b>0125</b>	<b>0160</b>	<b>0180</b>	<b>0215</b>	<b>0250</b>	<b>0320</b>	<b>0360</b>	<b>0414</b>	<b>0477</b>	<b>0515</b>	<b>0600</b>	<b>0720</b>	<b>0832</b>	<b>0900</b>	<b>0960</b>	<b>1065</b>
Max applicable motor line current (Inline) (A) - Standard Duty		15	23	28	34	44	52	65	78	87	96	110	125	160	180	215	250	320	360	414	477	515	600	720	832	900	960	1065
Max applicable motor line current (Inside Delta) (A) <sup>1</sup> - Standard Duty		25	40	48	58	76	89	112	134	150	166	190	216	276	311	371	432	553	622	716	825	890	1038	1245	1439	1557	1660	1842
<b>Control</b>	Control system	Digital 32-bit Digital Signal Controller																										
	Network connectivity	Supports RS-485 Modbus as standard, Profibus-DP (slave), DeviceNet, CANopen, Ethernet, ControlNet are optional.																										
<b>Operation Specifications</b>	Current feedback & Electronic OLR	Motor current: Adjustable up to 30 % of unit current										I-Trip Level: 100...800% of full load motor current					I-Limit Level: 100...600% of full load motor current											
		Low Level: 0...100% of full load motor current										I-Low Time: 0...20 minutes					I-Limit Time: 10...60 sec											
	Digital Inputs	4-Programmable Sequence Inputs, Sink / Source changeable, max 5 mA each Programmable between 17 different options: Not Used, Terminal, Jogging, External Fault, Fault Reset, Bypass Contactor, Main Contactor, E-Stop, Ramp Hold, Reverse Contactor, Run, Stop, Motor PTC, PLC I/P 1...4																										
	Potential Free Contacts	3-Programmable relays:										1-Relay: 1-NO for 5 A @ 240 VAC					2-Relay: 1-NO, 1-NC for 5 A @ 240 VAC											
		Programmable between 41 different options: Not Used, Ready, Run, Top of Ramp, Fault Alarm, I-Limit Alarm, Low Current Alarm, High Current Alarm, Temp Alarm, Reverse Contactor, Main Contactor, External Fan Control, Over Current Fault, Under Current Fault, I-Unbalance Fault, Overload Fault, Over Voltage Fault, Mains Off Fault, Phase Loss Fault, External Fault, Emergency Fault, Motor PTC Short Fault, Motor PTC Over Temperature, Power Not OK, Bypass Relay Fault, EEPROM Fault, Ground Fault, Phase Direction Fault, Over Freq Fault, Under Freq Fault, Thermistor OT Fault, Thermistor NC Fault, Thermostat NC Fault, Firing Fault, Thermistor Short Fault, SCR Short Fault, Watchdog Fault, PLC O/P 1...3																										
	Analog Outputs	2-Programmable analog current outputs AO1 & AO2: 4...20 mA with settable gain, bias, minimum and maximum scaling, 12-bit Programmable between 7 different options: Output Current, Active Power, Reactive Power, Power factor, Motor torque, Heat sink temperature, Motor PTC, PLC Analog output 1 and 2																										
Motor PTC Feedback	One or three Motor PTC can be connected for motor over temperature protection																											
<b>Operation Specifications</b>	Start Mode	V-Ramp Start	Dual Ramp Selection					V-Ramp Up Time 1: 1...240 sec					Pedestal-1: 25...90%															
			Kick Time: 0...2.0 sec					Kick Voltage: 0...90%					Target: 25...100%															
		I-Ramp Start	I-Ramp Up Time: 1...60					Initial Current: 100...300%					I-Proportional Gain: 0.01...2.00															
	I-Integral Time: 0.01...100.00																											
	T-Ramp Start	T-Ramp Up Time: 1...240 sec					Initial Torque: 1...250%					Torque Limit: 1...250%																
		T-Proportional Gain: 0.1...2.0																										
	Stop Mode	V-Ramp Stop	V-Ramp Down Time: 1...240 sec					Initial Voltage: 100...25%					Final voltage: 70...25%															
Brake Stop		Brake Ramp Time: 0.1...20.0 sec					Brake Voltage: 25...100%					Brake Time: 1...240 sec																
T-Ramp Stop		T-Ramp Down Time: 1...240 sec					T-Integral Time: 0.01...100.00																					
Coast to stop																												
Control Mode	Local (Digital Operation Panel), Terminal, Serial																											
<b>Display</b>	Display and Keypad module (Standard)	Digital Operation Panel 5 digit seven segment LED display with 2 decimal points, Unit indication, Start Mode, Start control, Bypass and Starter's status LEDs display, 9-Key Keypad, 3-LED for Run, Stop, Fault. 13 predefined normal parameter display; Can be mounted on panel door with optional extension cable.																										
	Graphical Display and Keypad unit (Optional)	Digital Operation Panel 128x64 Graphical LCD with white back light LED, 9-Key Keypad, 3-Status indicating LED for Run, Stop, Fault   Real Time Clock Simultaneous display of 8 selectable monitor parameters Two graph screens with selectable graph signal and resolution Auto rotation of screens with settable time interval Can be mounted on panel door with optional extension cable																										
<b>Start Duty</b>	Overload Duty	10 equally spaced starts per hour at 350% current, each of 30 seconds duration, i.e. 30 seconds on time and 330 second off time. For models -0720A to -1065A, 6 equal start.																										
		10 equally spaced starts per hour at 500% current, each of 15 seconds duration, i.e. 15 seconds on time and 345 second off time. For models -0720A to -1065A, 6 equal start.																										
		10 equally spaced starts per hour at 500% current, each of 30 seconds duration, i.e. 30 seconds on time and 340 second off time. For models -0720A to -1065A, 6 equal start. Contact AMTECH for derating information.																										
Utilization Category	AC53a or AC53b																											
<b>Protection</b>	Diagnostic fault and protection	Over current fault					Over voltage fault					Temperature fault					Reverse contactor fault											
		Over load fault					SCR Short fault					Phase direction fault					Main contactor fault											
		Ground fault					Over frequency fault					I-Unbalance fault					Bypass contactor fault											
		Phase Loss fault					Under frequency fault					Firing fault																
		Mains off fault					Motor PTC fault					Watchdog fault																
<b>Environment</b>	Installation Location	Indoor																										
	Ambient Temperature	-15...50 °C (5...122 °F)																										
	Storage Temperature	-20...70 °C (-4...158 °F)																										
	Altitude (above sea level)	1000 m (3300 ft) without derating, above this derate 3% per 305 m (1000 ft) up to 4000 m																										
	Humidity	0...95% max non condensing																										
Enclosure	IP20 up to 110A model, after that IP00 (other can be provided on demand)																											
<b>Reference Standards</b>		UL 508, UL 60947-4-2, CSA C22.2 60947-4-2, IEC 60947-4-2, IEC 60947-1, CE (EN 60947-4-2), IEC 60529																										

1: Contact Amtech for Inside Delta option up to 360 A in AMT-OT-iB series above 480V input.

# Typical Connection Diagram

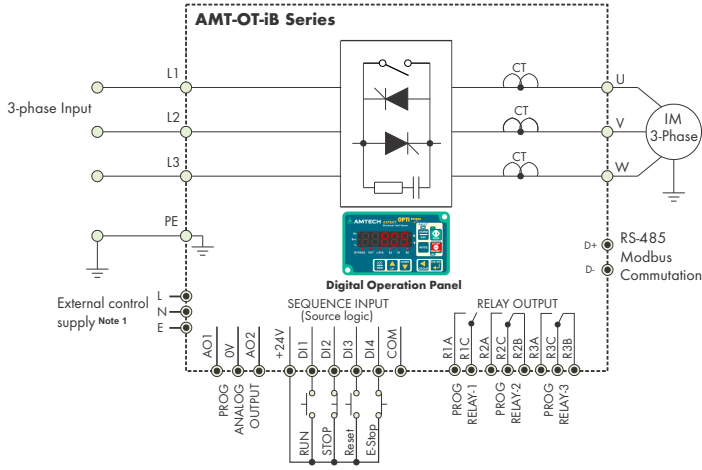

**In-line configuration**

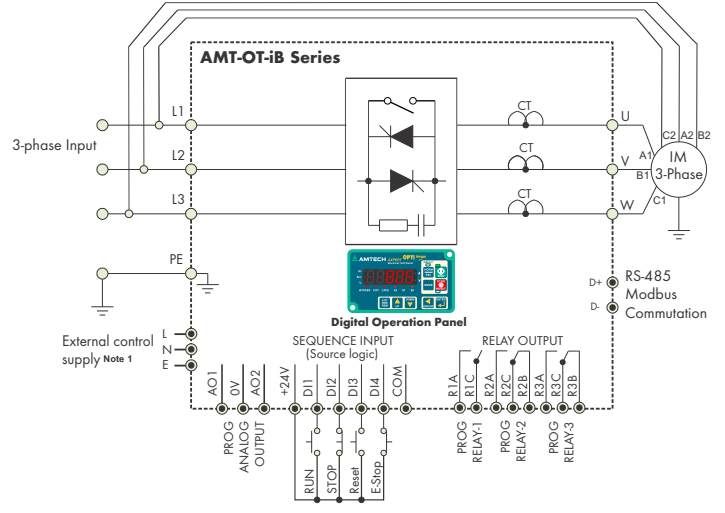

**Inside Delta configuration**

**Note:**

1. Control supply 1-phase, 50/60 Hz, 90...270 VAC or 115/230 VAC to be provided by customer. Refer ordering code.

## Display Options

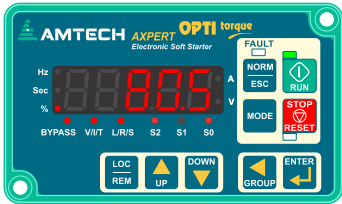

**LED Display (Standard)**

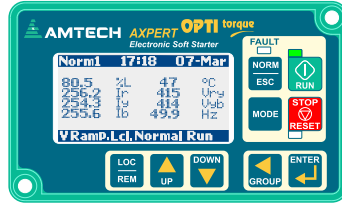

**Graphical LCD Display (Optional)**

## Model Number

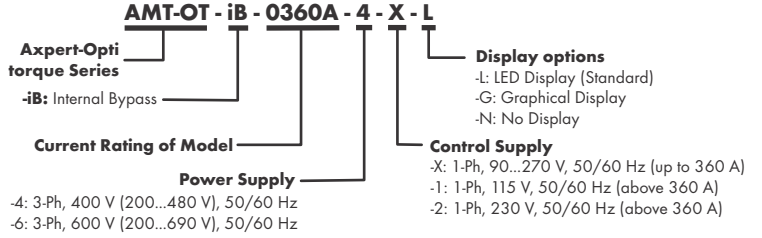

## Outline Dimensions

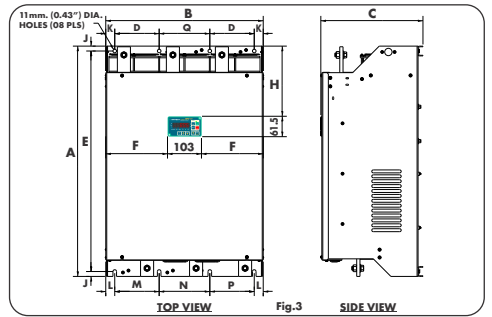
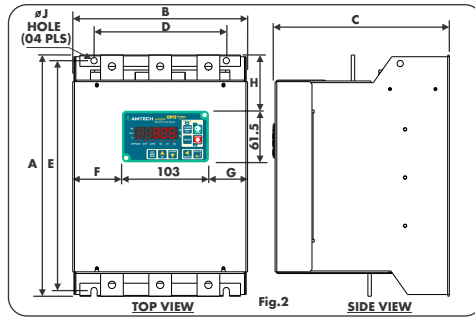
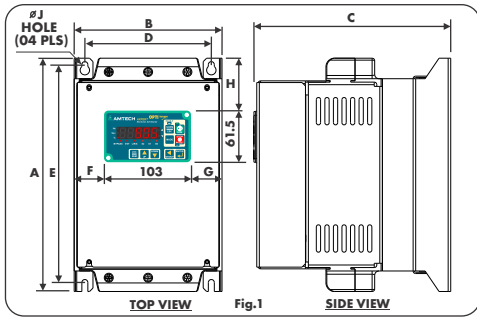

Model	Dimensions in mm (Inch)										Weight in kg (lb)
	A	B	C	D	E	F	G	H	J		
<b>AMT-OT-iB-0015A, -0023A, -0028A, -0034A, -0044A, -0052A, -0065A, -0078A, -0087A, -0096A, -0110A</b>											
<b>Fig.1</b>	273 (10.75)	173 (6.81)	230 (9.05)	148 (5.83)	255 (10.04)	35 (1.38)	35 (1.38)	61.5 (2.42)	7 (0.28)	6.7 (14.8)	
<b>AMT-OT-iB-0125A, -0160A, -0180A, -0215A</b>											
<b>Fig.2</b>	393 (15.47)	308 (12.13)	274.5 (10.81)	233 (9.17)	373 (14.69)	102 (4.02)	102 (4.02)	111 (4.37)	11 (0.43)	19 (41.9)	
<b>AMT-OT-iB-0250A, -0320A, -0360A</b>											
<b>Fig.2</b>	425 (16.73)	308 (12.13)	310.5 (12.22)	233 (9.17)	405 (15.94)	102 (4.02)	102 (4.02)	120 (4.72)	11 (0.43)	23 (50.7)	

Model	Dimensions in mm (Inch)														Weight in kg (lb)
	A	B	C	D	E	F	H	J	K	L	M	N	P	Q	
<b>AMT-OT-iB-0414A, -0477A, -0515A, -0600A</b>															
<b>Fig.3</b>	705 (27.7)	482 (19.0)	312.5 (12.3)	136 (5.3)	675 (26.5)	189.5 (7.4)	214 (8.4)	15 (0.6)	25 (1.0)	25 (1.0)	136 (5.3)	155 (6.1)	136 (5.3)	155 (6.1)	67 (147.7)
<b>AMT-OT-iB-0720A, -0832A, -0900A, -0960A, -1065A</b>															
<b>Fig.3</b>	830 (32.7)	578 (22.7)	358.5 (14.1)	173 (6.8)	800 (31.5)	237.5 (9.3)	316 (12.4)	15 (0.6)	25 (1.0)	25 (1.0)	173 (6.8)	177 (7.0)	173 (6.8)	177 (7.0)	112 (246.9)

Contact Amtech for dimension detail

# OUR OTHER OFFERINGS

## MOTOR CONTROL



### "DRIVE FOR SUCCESS"

We provide complete motor control system solutions or individual system components to address industry specific requirements and optimize your process.

Our solutions are simple, compatible and environment friendly, resulting in efficient production, cost optimization and minimizing human intervention. It even leads to energy conservation especially in typical Fan, Blower, Pump applications.

#### Flagship Solutions

- Axpert-Eazy+ Series VFD
- Axpert-VT240S Series VFD
- Axpert-Hivert Series Medium Voltage Drive
- Axpert-Opti torque Series Soft Starter
- Axpert-Eazy HF Series High Frequency Drive

#### Applications

- Fans, Blowers, Pumps
- Compressors, Centrifuges
- Agitators & Conveyors
- Crane, Hoist & Elevator
- Rolling Mill, Sugar Mill, Pulp Mill, Coal/Raw Mill

## AUTOMATION



MACHINE AUTOMATION

LINE AUTOMATION

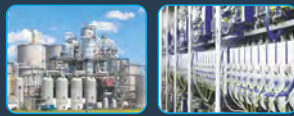

PLANT AUTOMATION

NETWORKING AUTOMATION

### "AUTOMATION. MADE EASY"

"Automation Made Easy" is our philosophy to simplify the increasing complexity of modern production systems through our Amtech-Jetter PROCESS PLC technology platform.

Over 30 years experience in Machine, Line, Plant and Networking Automation has helped us to find the best solution in terms of functionality, sustainability and efficiency.

#### Flagship Solutions

Jet Control series PLC Controllers, Expansion Modules, Jet view Soft SCADA, HMIs, Jet Move series Servo and Axes Control System.

#### Applications

- Paper Machine Automation
- Textiles Manufacturing
- Packaging
- Winder Machine
- Crane & Material Handling Equipment
- CNC Machines
- Semiconductor Assembly Line
- Retrofit solutions

## POWER QUALITY



ACTIVE HARMONIC FILTER

WIDEBAND HARMONIC FILTER



ACTIVE FRONT END CONVERTER

STATCON: MULTIFUNCTIONAL ACTIVE STATIC VAR COMPENSATOR

### "ONE STOP SOLUTION TO QUALITY POWER"

Amtech's Power Quality Solutions offer you the synergy of multiple benefits - energy conservation, enhanced operational efficiency and reliability through a dedicated range of products and services.

#### Products

- Axpert-i-Sine Series Active Front-end Converter
- Axpert-i-Sine Series Active Harmonic Filter (AHF)
- Axpert-i-Sine Series Active Static VAR Compensator (STATCON)
- Harmonic Reactor
- Sinus Filter
- EMI/RFI Filter

#### Services

- Harmonic Audit and Solutions to comply with IEEE-519 standard
- System design, optimization & payback analysis
- Consultancy for Power Quality improvement
- Training on Power Quality Management
- Energy Audit and solutions by experienced BEE certified professionals

## INDUSTRIAL ELECTRONICS

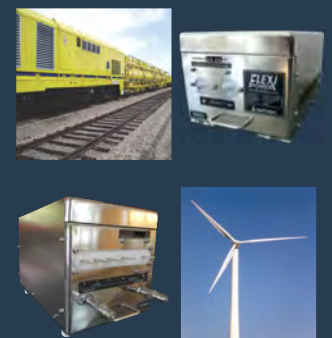

### "YOUR TECHNOLOGY PARTNER"

Amtech's Power Electronics Engineering Services offer technology solutions to independent R&D labs, industrial segments like Traction, Oil & Gas, Automotive and Renewable Energy for wind to reduce your time to market.

#### Products

- Traction Drive
- High Voltage Power Supply
- Battery back-up drive & systems for critical loads
- Wind Power Converter
- Digital Heater Controller
- Battery Charger
- Drive Train

#### Services

- Power Electronics Engineering Services
- Customized solutions for industry specific applications
- Solution for Oil, Gas & Mining
- Power Electronics product development & testing
- Product verification & validation
- Retrofit Solutions



AMTECH ELECTRONICS (INDIA) LTD.

**DRIVE FOR SUCCESS**

E-6, GIDC Electronics Zone, Gandhinagar - 382028, Gujarat, India.  
 Phone: +91-79-23289101, 23289102, 23289103 | Fax: +91-79-23289111  
 Email: info@amtechelectronics.com | Website: www.amtechelectronics.com  
 Specifications in this catalog are subject to change without notice